



C165 HD

165 Ah | 12 V | 1030 A

Elektrische Eigenschaften

Nennspannung	12 V
Nennkapazität (20 h)	165 Ah (25 °C, 10,5 V)
CCA (EN -18 °C)	1030 A
CCA (DIN -18 °C)	570 A

Mechanische Eigenschaften

Maße (L x B x H)	513 x 218 x 212 mm
Gewicht	41,3 kg
Halterung	B03
Layout	3
Anschluss	1
Stopfen	M27
Technologie	Nass
Gehäusematerial	PP (schwarz)
Deckelmaterial	PP (schwarz)

Technische Eigenschaften

Elektrolyt	H ₂ SO ₄
Elektrolyt Dichte (25 °C)	1,28 ± 0,01 g/cm ³
Anzahl der Platten	22 (11+, 11-)
Positives Gitter	PbSb
Negatives Gitter	PbCa
Separator	PE (1,4 mm)

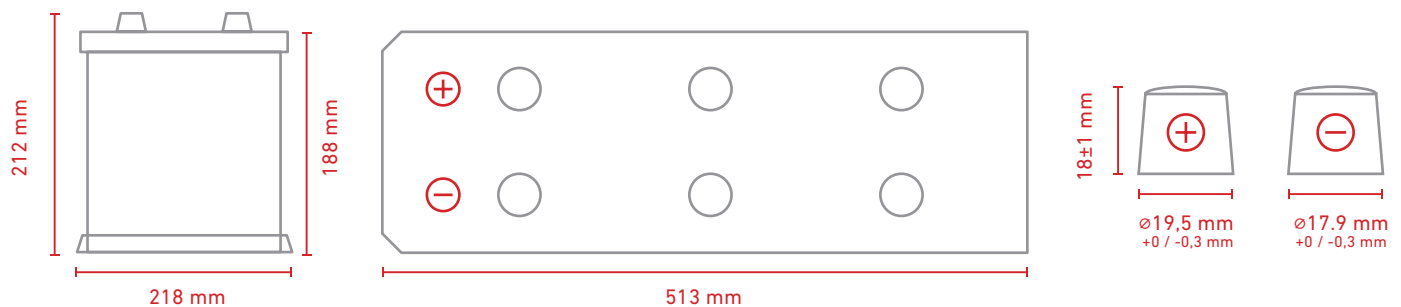

VIBRATION RESISTANT



-18°C TESTED



LOW MAINTENANCE



95% RECYCLABLE



LONG LIFE



BUILT WITH GREEN ENERGY



MADE IN EUROPE

